

### Galvanized Tie Wire and Hanger Wire

Project Submittals as manufactured by  
ALABAMA METAL INDUSTRIES CORPORATION

Submittal Date:

Contract Number:

Project Name:

Section Number:

Contractor's Name:

---

All information contained herein is accurate as known at the time of publication. Specifications may change and AMICO reserves the right to change product specifications without notice and without incurring obligations.

**ALABAMA METAL INDUSTRIES CORPORATION**

3245 Fayette Avenue ♦ Birmingham, AL 35208 ♦ Telephone 800/366-2642 ♦ Facsimile 205/786-6527  
email [fmayer@gibraltar1.com](mailto:fmayer@gibraltar1.com)



## GALVANIZED STEEL TIE WIRE AND HANGER WIRE

meeting ASTM A641

### SCOPE

This submittal covers wire for hanging and tying support CRC, Cold Rolled Channel gridwork for stucco, acoustical or drywall ceilings. The selection of the accessory shall be determined by numerous factors not limited to: the project location, climate and environment resulting from excessive salt, moisture, humidity, pollution, wear and temperature changes.

### MATERIALS

Class 1 Coated (Hot Dip Galvanized) Wire

### THICKNESS OF BASE MATERIALS

Minimum thicknesses meet ASTM C1063 Section

### FINISH

Hot Dip Galvanized

### PACKAGING AND PACKAGE MARKING

Tie Wire is generally available in 28-inch lengths weighing 25-lbs per hank.

Straight and cut Hanger Wire is generally available in 12-ft lengths weighing 50-lbs per hank. Each factory hank shall be marked with manufacturer's name and wire diameter.

### CERTIFICATION

When required a certification that products meets the requirements of ASTM A641 shall be provided.

### AMICO GALVANIZED WIRE MEETS THE FOLLOWING SPECIFICATIONS

ASTM A641 Standard Specification for  
Zinc-Coated (Galvanized) Carbon Steel Wire

ASTM C1063 Standard Specification for Installation  
of Lathing and Furring to Receive Interior and Exterior  
Portland Cement-Based Plaster

ASTM C1047 Standard Specification for Accessories  
for Gypsum Wallboard and Gypsum Veneer Base

Country of Origin - Import from various countries

All information contained herein is accurate as known at the time of publication. Specifications may change and AMICO reserves the right to change product specifications without notice and without incurring obligations.

### ALABAMA METAL INDUSTRIES CORPORATION

3245 Fayette Avenue ♦ Birmingham, AL 35208 ♦ Telephone 800/366-2642 ♦ Facsimile 205/786-6527  
email [fmayer@gibaltar1.com](mailto:fmayer@gibaltar1.com)

2012



## 18GA (0.0475-in.) GALVANIZED STEEL TIE WIRE Class 1 Coated Annealed Dead Soft

meeting ASTM A641

This submittal covers wire to support CRC, cold formed channel used to support gridwork for stucco, acoustical and drywall ceilings.

Submitted Product	Product Number	Diameter		Length
	TW18	18GA	0.0475 in	28-in.
Class 1 zinc coating and soft annealed for easy tying				

Refer to ASTM C754 for support spacing, fastener selection and further information regarding the proper installation with gypsum panel products.

Refer to ASTM C1063 for support spacing, fastener selection and further information regarding the proper installation with metal lath.

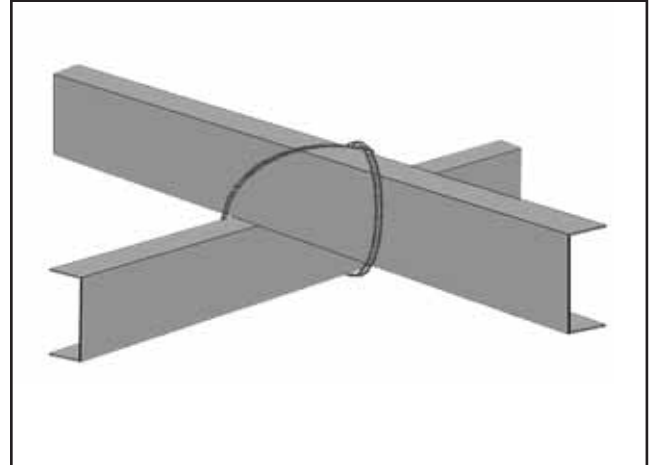

All information contained herein is accurate as known at the time of publication. Specifications may change and AMICO reserves the right to change product specifications without notice and without incurring obligations.

### ALABAMA METAL INDUSTRIES CORPORATION

3245 Fayette Avenue ♦ Birmingham, AL 35208 ♦ Telephone 800/366-2642 ♦ Facsimile 205/786-6527  
email [fmayer@gibraltar1.com](mailto:fmayer@gibraltar1.com)

2012



## 8GA, 9GA and 12GA GALVANIZED STEEL HANGER WIRE

meeting ASTM A641

This submittal covers wire to for tying support Cold Rolled Channel, (CRC) used in the installation of the support horizontal and vertical gridwork for stucco, acoustical or drywall ceilings. The selection of the accessory shall be determined by numerous factors not limited to: the project location, climate and environment resulting from excessive salt, moisture, humidity, pollution, wear and building aesthetics.

Submitted Product	Product Number	Diameter		Length
	HW8	8GA	0.1620-in.	12-ft.
	HW9	9GA	0.1480-in.	12-ft.
	HW12	12GA	0.1055-in.	12-ft.
Class 1 zinc coating and soft annealed for easy tying				

Refer to ASTM C754 for support spacing, fastener selection and further information regarding the proper installation with gypsum panel products.

Refer to ASTM C1063 for support spacing, fastener selection and further information regarding the proper installation with metal lath.

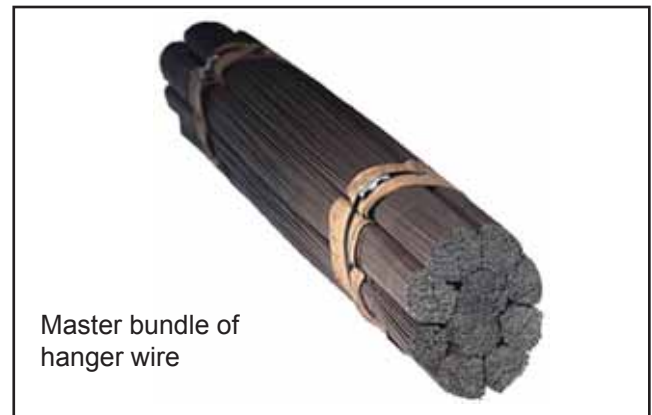
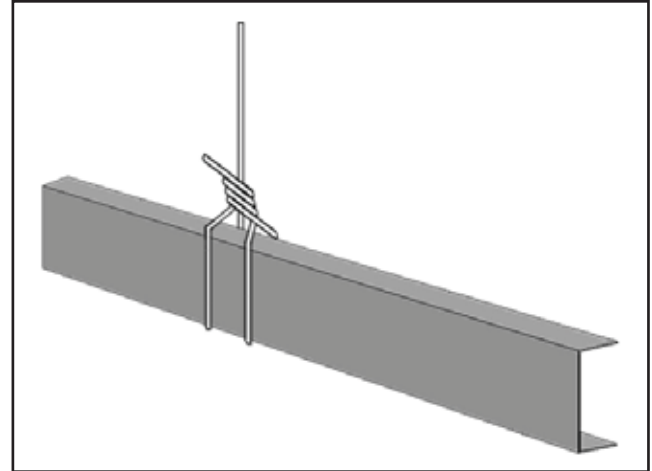

All information contained herein is accurate as known at the time of publication. Specifications may change and AMICO reserves the right to change product specifications without notice and without incurring obligations.

### ALABAMA METAL INDUSTRIES CORPORATION

3245 Fayette Avenue ♦ Birmingham, AL 35208 ♦ Telephone 800/366-2642 ♦ Facsimile 205/786-6527  
email [fmayer@gibraltar1.com](mailto:fmayer@gibraltar1.com)

